

PARTS LIST			
ITEM	PART#	DESCRIPTION	NOTES
1	K1927	2Part 8in Single Face Body	Assembly
2	K1939	2Part Large Ext. Retainer	Assembly
3	K1959/41	2Part Large Inner/Outer Frame	Assembly
4	5980	Header/Reader Divider Angle	
26	5290	2Part Large Ext. Retainer Screw	Drill 1/8" pilot hole
66	5290	Combo Divider Screw	Drill 1/8" pilot hole

Ship To:  
Sales Order#:

ATTACHMENT TO  
INNER BODY  
FLANGE

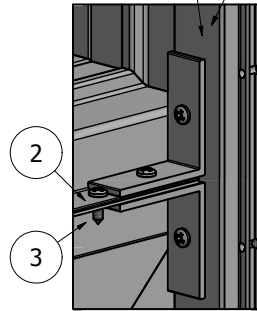

DETAIL A-2

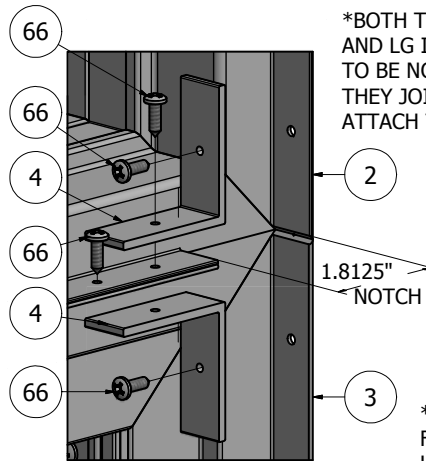

DETAIL A-1

\*BOTH THE LG EXT. FRAME  
AND LG INNER FRAME NEED  
TO BE NOTCHED WHERE  
THEY JOIN IN ORDER TO  
ATTACH TO THE BODY.

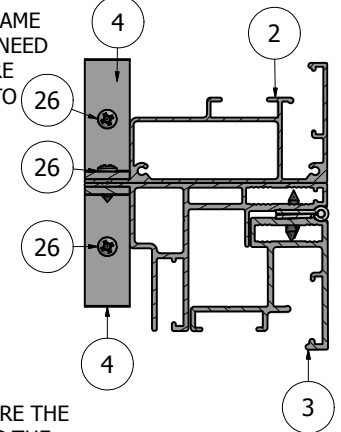

\*ANGLES SECURE THE  
FRAMES ALONG THE  
HORIZONTALS WHERE THEY  
JOIN TOGETHER.

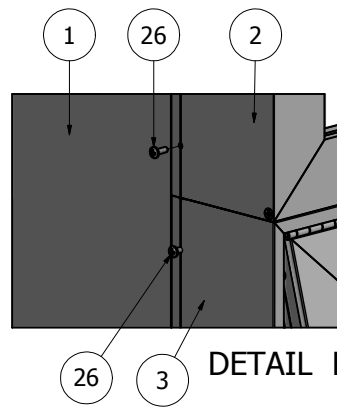
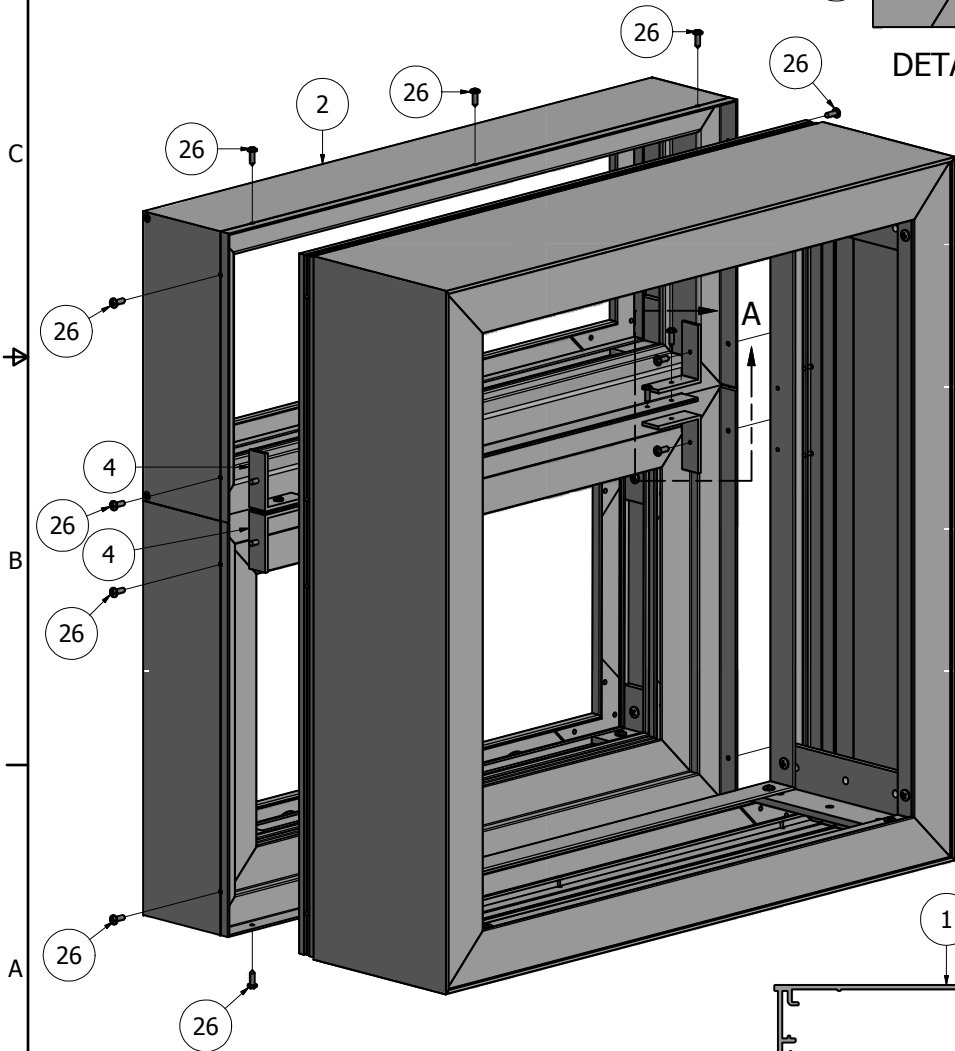

DETAIL B

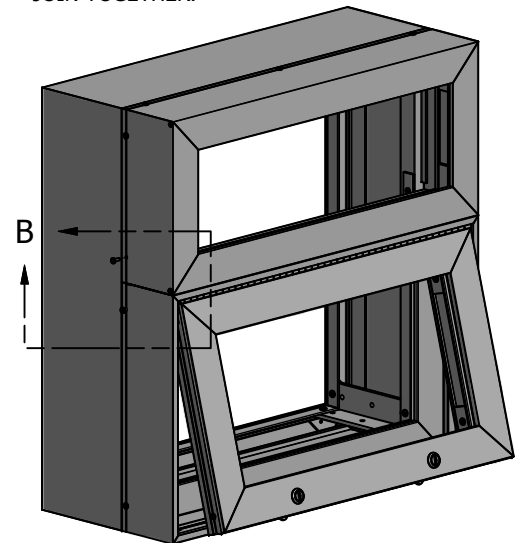

**NOTE: PRE-CUT KITS ARE NOT PRE-DRILLED.**

(Holes shown in this drawing are for reference only.  
Drilling of pilot holes are to be done by fabricator.)

THIS DRAWING WAS CREATED AT NO CHARGE TO ASSIST YOU IN VISUALIZING OUR PROPOSAL. THE DRAWING HEREIN IS THE PROPERTY OF SIGNCOMP. PERMISSION TO COPY OR REVISE THIS DRAWING OR TO USE THIS DRAWING FOR PRODUCTION IS STRICTLY PROHIBITED AND CAN ONLY BE COPIED, REVISED OR USED FOR PRODUCTION WITH THE EXPRESSED WRITTEN PERMISSION OF SIGNCOMP.

DRAWN	SBreihof	8/22/2012
Centroid X:	0.000 in	
Centroid Y:	0.000 in	
Principal Moments Ix:	0.000 in <sup>4</sup>	
Principal Moments Iy:	0.000 in <sup>4</sup>	
Section Modulus Ix:	0.000 in <sup>3</sup>	
Section Modulus Iy:	0.000 in <sup>3</sup>	

**SignComp**

TITLE  
2Part 8in Single Face Body w/ 2Part Large  
Ext. Retainer and 2Part Large Vandal -  
Assembly

DWG NO **K1927/39/59/41** REV

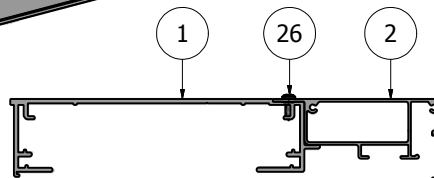

TOP CROSS-SECTION

PARTS LIST			
ITEM	PART #	DESCRIPTION	NOTES
1	1927	2Part 8in Single Face Body	Top & Bottom
2	1927	2Part 8in Single Face Body	Left Side
3	1927	2Part 8in Single Face Body	Right Side
4	5979	Body Corner Angle	
5	5210	Corner Key	
13	5218	Corner Angle Screw	Drill 5/32" pilot hole

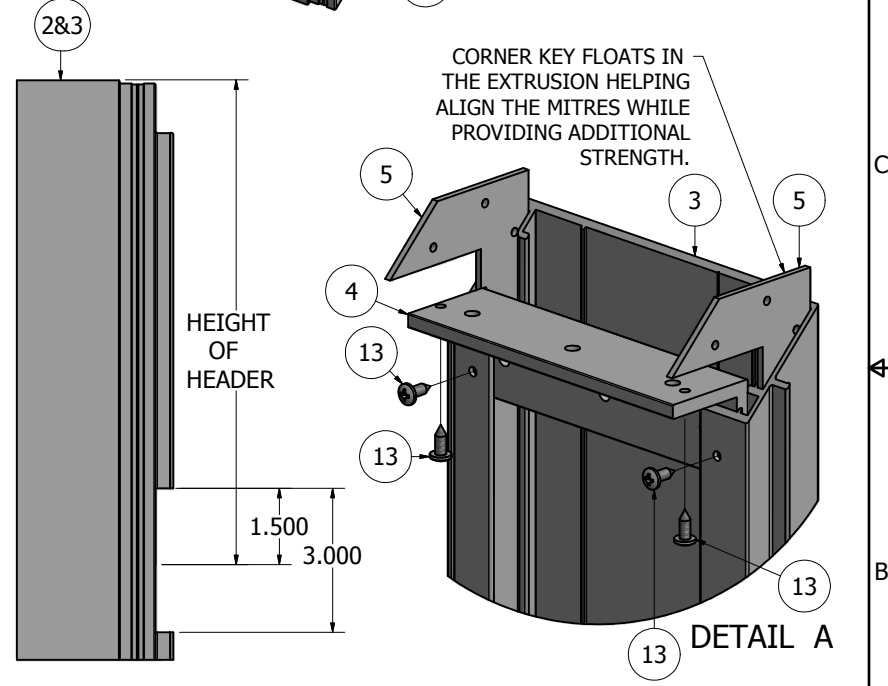
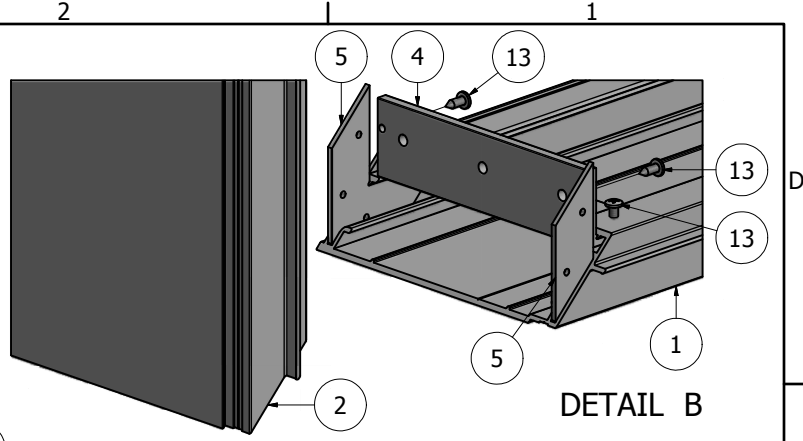
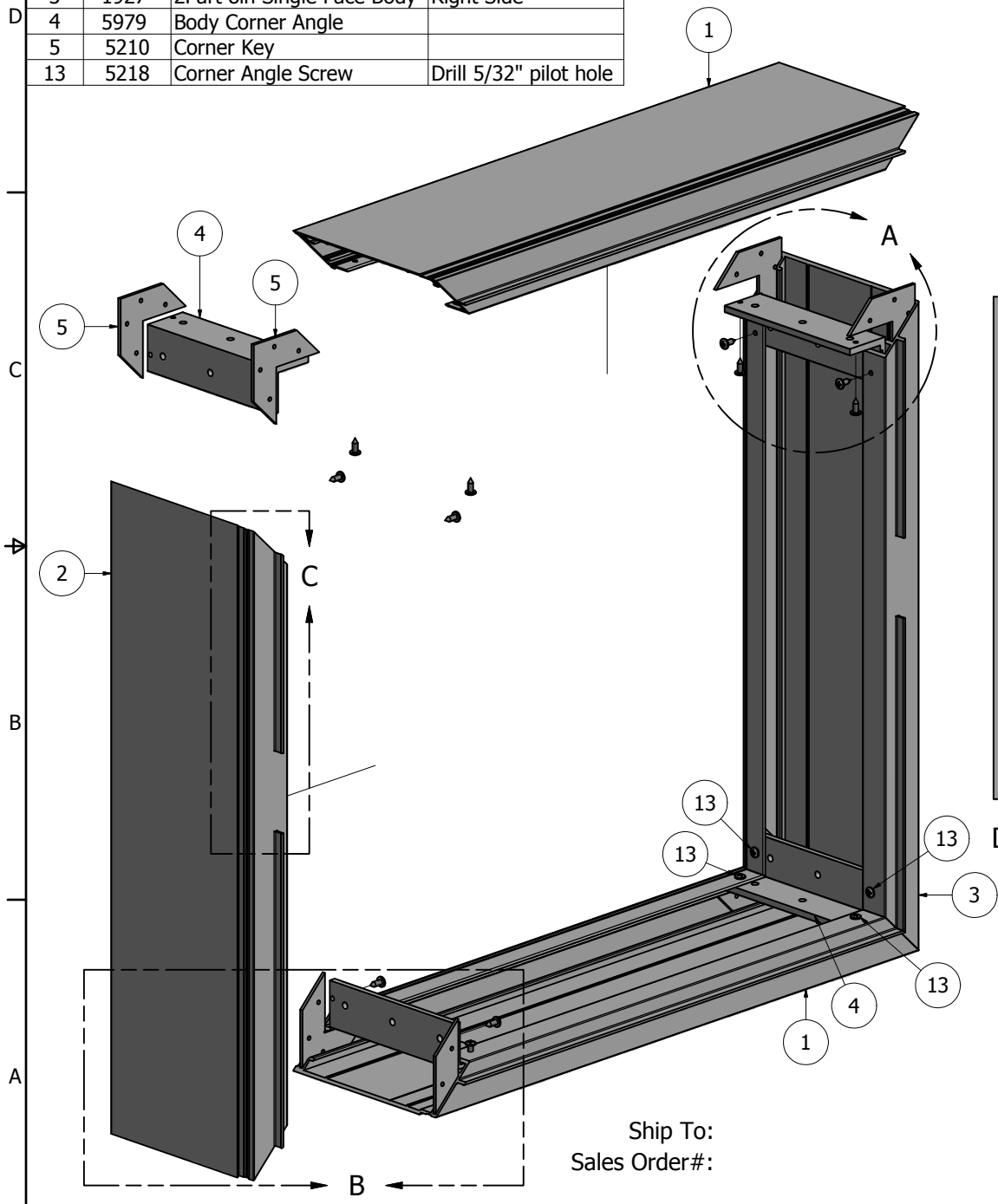

DETAIL C

**NOTE: PRE-CUT KITS ARE NOT PRE-DRILLED.**  
 (Holes shown in this drawing are for reference only.  
 Drilling of pilot holes are to be done by fabricator.)

THIS DRAWING WAS CREATED AT NO CHARGE TO ASSIST YOU IN VISUALIZING OUR PROPOSAL. THE DRAWING HEREIN IS THE PROPERTY OF SIGNCOMP. PERMISSION TO COPY OR REVISE THIS DRAWING OR TO USE THIS DRAWING FOR PRODUCTION IS STRICTLY PROHIBITED AND CAN ONLY BE COPIED, REVISED OR USED FOR PRODUCTION WITH THE EXPRESSED WRITTEN PERMISSION OF SIGNCOMP.			
DRAWN	SBreihof	7/13/2012	
Centroid X:	0.000 in	TITLE	
Centroid Y:	0.000 in		
Principal Moments Ix:	0.000 in <sup>4</sup>	2Part 8in Single Face Body - Notched Assembly	
Principal Moments Iy:	0.000 in <sup>4</sup>		
Section Modulus Ix:	0.000 in <sup>3</sup>	DWG NO	REV
Section Modulus Iy:	0.000 in <sup>3</sup>	<b>K1927 - Header / Reader</b>	
			SHEET 1 OF 1

Ship To:  
Sales Order#:

PARTS LIST			
ITEM	PART#	DESCRIPTION	NOTES
1	1939	2Part Large Extended Retainer	Top & Bottom
2	1939	2Part Large Extended Retainer	Sides
3	5210	Corner Key	
4	5305	Frame Corner Angle	
29	5241	2Part Large Ext. Retainer Corner Screw	Drill #8 counter sink

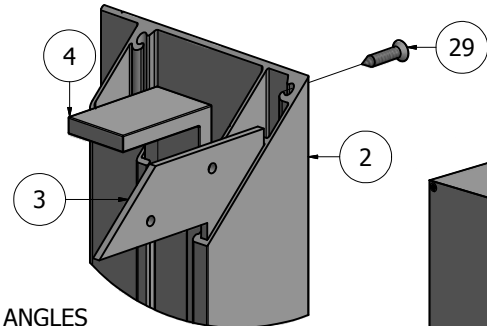

DETAIL A

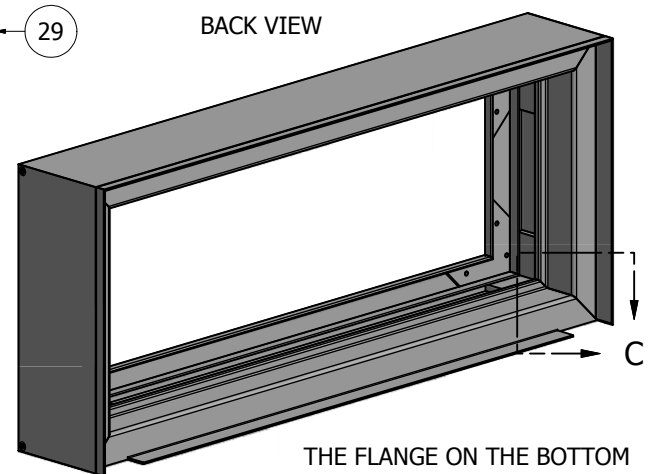

BACK VIEW

THE FLANGE ON THE BOTTOM HORIZONTAL IS NOTCHED ON BOTH ENDS IN ORDER TO FIT AROUND THE BODY FOR ATTACHMENT.

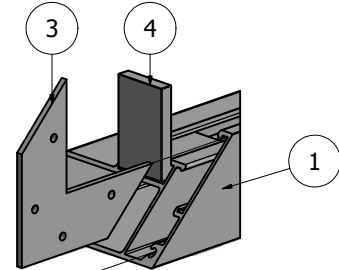

DETAIL B

FRAME CORNER ANGLES AND CORNER KEYS FLOAT IN THE EXTRUSION TO HELP ALIGN THE MITRES AND ADD STRENGTH.

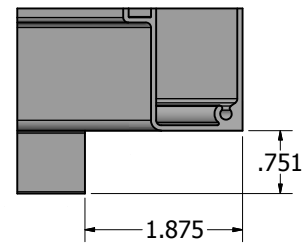

DETAIL C-2

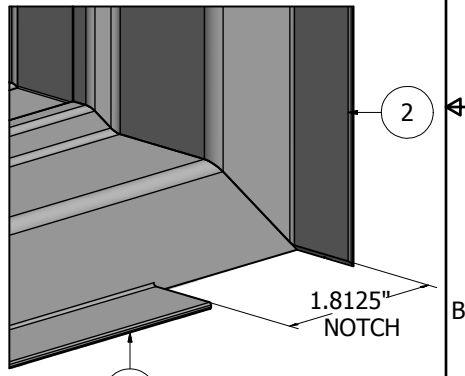

DETAIL C-1

**NOTE: PRE-CUT KITS ARE NOT PRE-DRILLED.**  
(Holes shown in this drawing are for reference only. Drilling of pilot holes are to be done by fabricator.)

THIS DRAWING WAS CREATED AT NO CHARGE TO ASSIST YOU IN VISUALIZING OUR PROPOSAL. THE DRAWING HEREIN IS THE PROPERTY OF SIGNCOMP. PERMISSION TO COPY OR REVISE THIS DRAWING OR TO USE THIS DRAWING FOR PRODUCTION IS STRICTLY PROHIBITED AND CAN ONLY BE COPIED, REVISED OR USED FOR PRODUCTION WITH THE EXPRESSED WRITTEN PERMISSION OF SIGNCOMP.

DRAWN	SBreihof	7/26/2012
Centroid X:	0.000 in	
Centroid Y:	0.000 in	
Principal Moments Ix:	0.000 in <sup>4</sup>	
Principal Moments Iy:	0.000 in <sup>4</sup>	
Section Modulus Ix:	0.000 in <sup>3</sup>	
Section Modulus Iy:	0.000 in <sup>3</sup>	

<b>SignComp</b>		TITLE
		2Part Large Extended Retainer - Header
DWG NO	<b>K1939 - Header</b>	REV
SHEET 1 OF 1		

Ship To:  
Sales Order#:

D  
C  
B  
A

D  
C  
B  
A

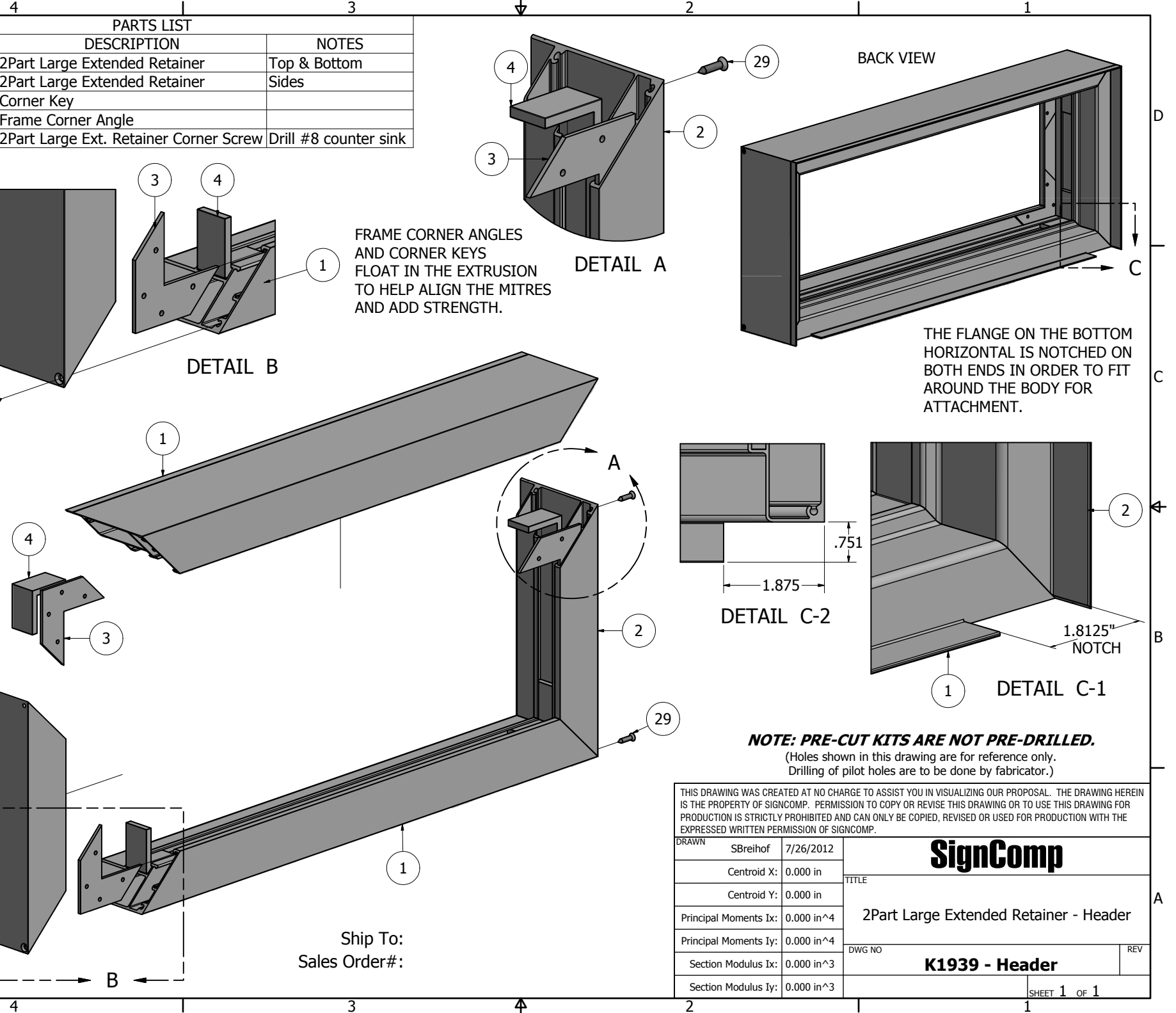

PARTS LIST			
ITEM	PART#	DESCRIPTION	NOTES
1	1959	2Part Large Inner Frame	Top & Bottom Sides
2	1959	2Part Large Inner Frame	Sides
3	5210	Corner Key	
4	5305	Frame Corner Angle	
67	5990	2Part Large Inner Frame Corner Angle Screw	Drill #8 Countersink

Ship To:  
Sales Order#:

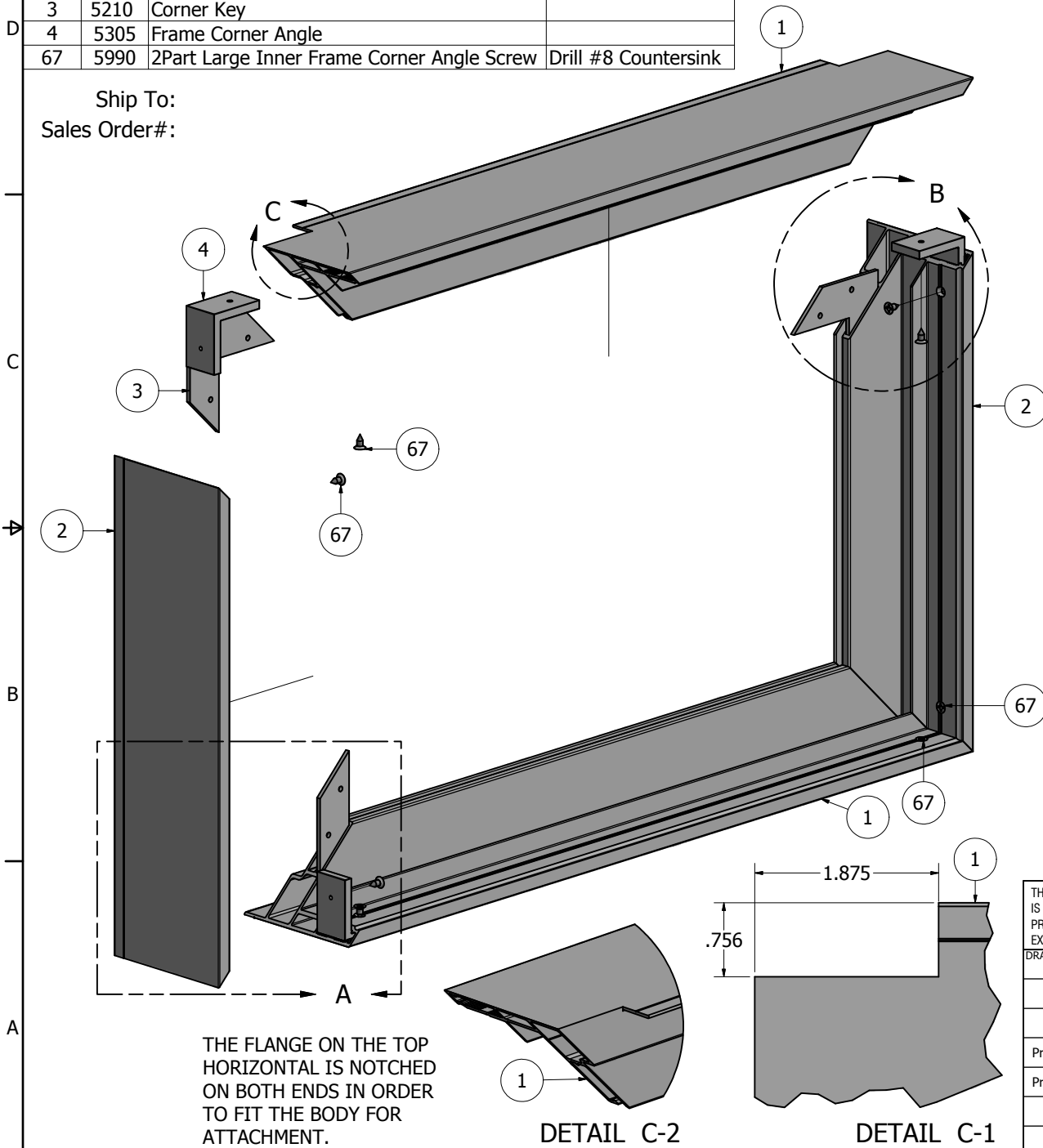

THE FLANGE ON THE TOP HORIZONTAL IS NOTCHED ON BOTH ENDS IN ORDER TO FIT THE BODY FOR ATTACHMENT.

DETAIL C-2

DETAIL C-1

CORNER KEYS FLOAT IN THE FRAME HELPING TO ALIGN THE MITRES WHILE PROVIDING ADDITIONAL STRENGTH.

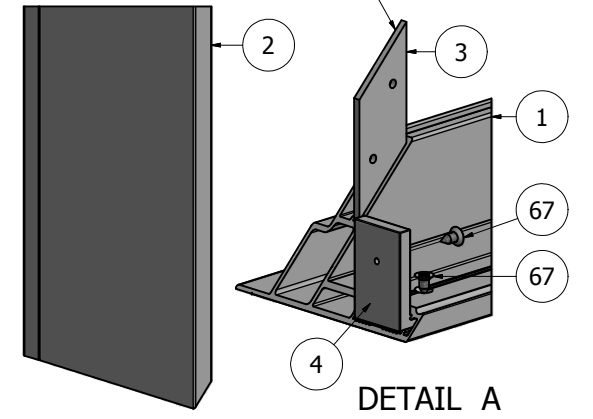

DETAIL A

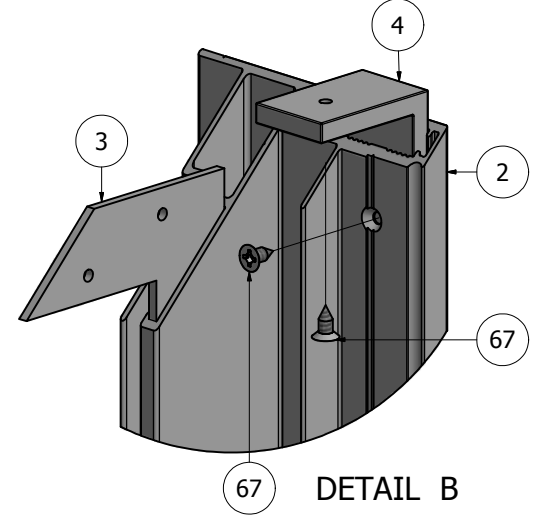

DETAIL B

**NOTE: PRE-CUT KITS ARE NOT PRE-DRILLED.**  
(Holes shown in this drawing are for reference only. Drilling of pilot holes are to be done by fabricator.)

THIS DRAWING WAS CREATED AT NO CHARGE TO ASSIST YOU IN VISUALIZING OUR PROPOSAL. THE DRAWING HEREIN IS THE PROPERTY OF SIGNCOMP. PERMISSION TO COPY OR REVISE THIS DRAWING OR TO USE THIS DRAWING FOR PRODUCTION IS STRICTLY PROHIBITED AND CAN ONLY BE COPIED, REVISED OR USED FOR PRODUCTION WITH THE EXPRESSED WRITTEN PERMISSION OF SIGNCOMP.		
DRAWN	SBreihof	7/27/2012
Centroid X:	0.000 in	
Centroid Y:	0.000 in	
Principal Moments Ix:	0.000 in <sup>4</sup>	
Principal Moments Iy:	0.000 in <sup>4</sup>	
Section Modulus Ix:	0.000 in <sup>3</sup>	
Section Modulus Iy:	0.000 in <sup>3</sup>	
<div style="text-align: center;"><b>SignComp</b></div>		TITLE
		2Part Large Inner Frame - Reader - Assembly
DWG NO		REV
<b>K1959 - Reader</b>		
SHEET 1 OF 1		

PARTS LIST			
ITEM	PART #	DESCRIPTION	NOTES
1	1941	2Part Large Outer Frame	Top & Bottom
2	1941	2Part Large Outer Frame	Sides
3	5210	Corner Key	
4	5305	Frame Corner Angle	
13	5218	Corner Angle Screw	Drill #10 pilot hole
30	5990	Outer Frame Corner Angle Screw	Drill #8 Counter Sink

D  
C  
B  
A

4 3 2 1

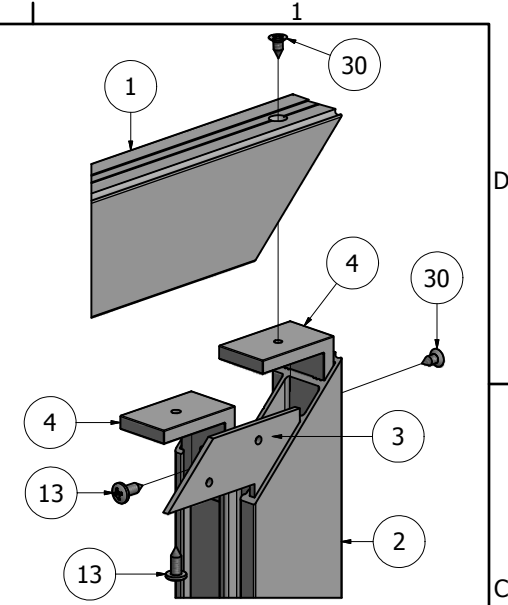
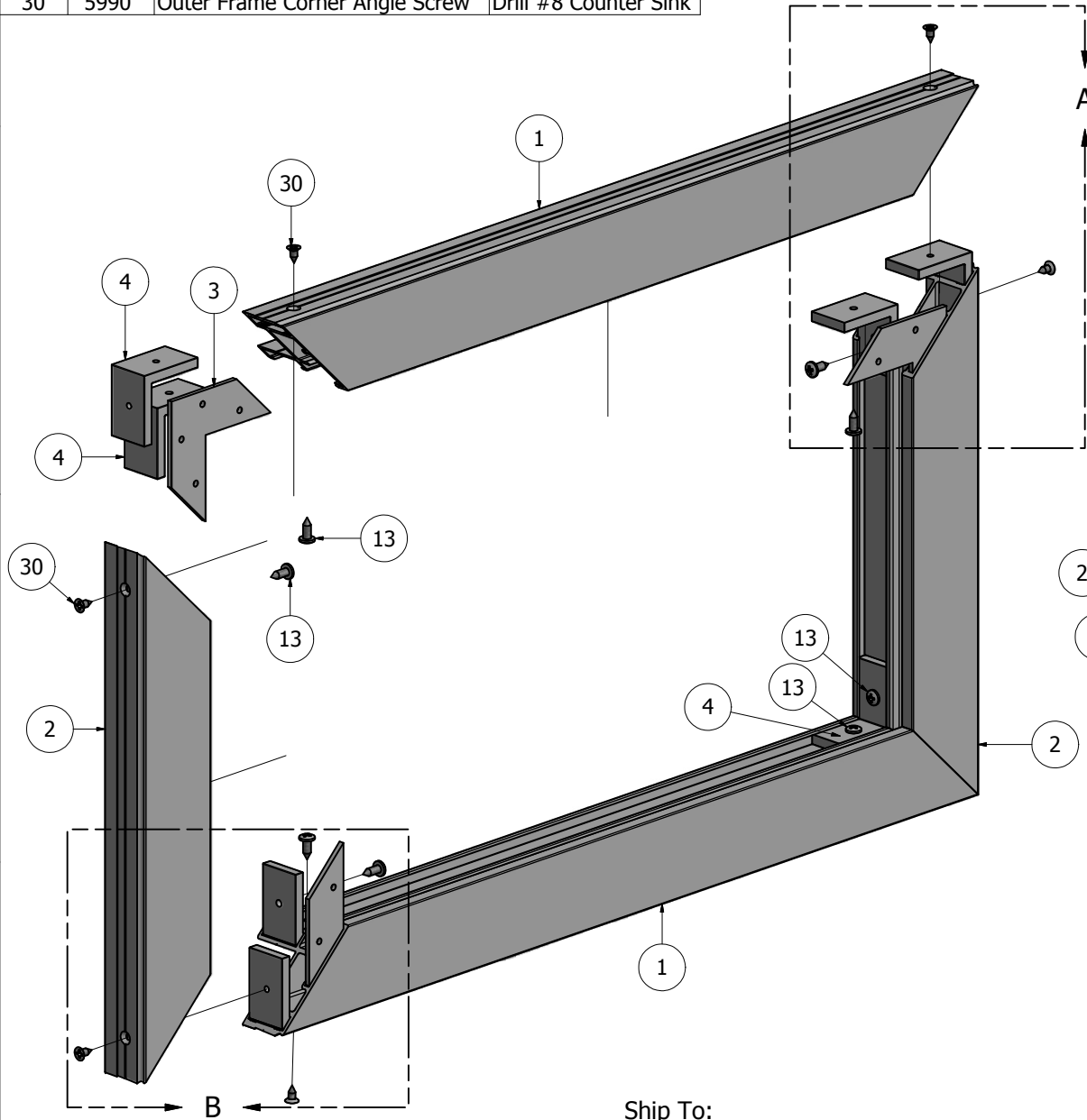

DETAIL A

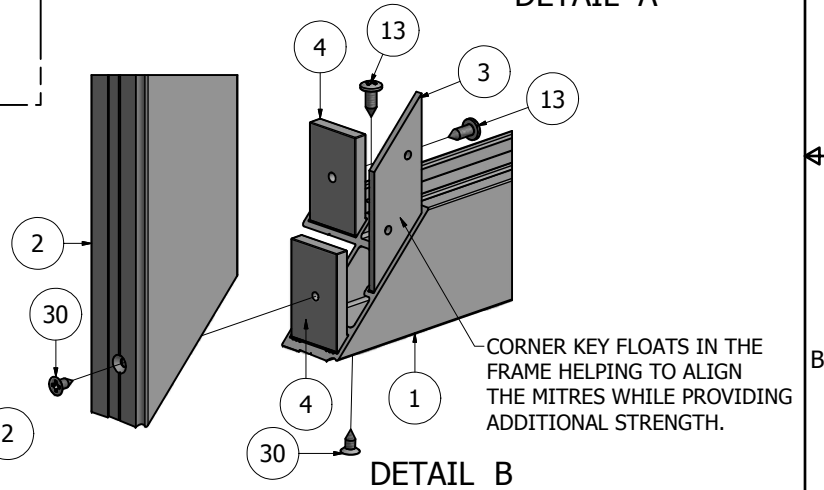

CORNER KEY FLOATS IN THE FRAME HELPING TO ALIGN THE MITRES WHILE PROVIDING ADDITIONAL STRENGTH.

DETAIL B

**NOTE: PRE-CUT KITS ARE NOT PRE-DRILLED.**  
(Holes shown in this drawing are for reference only. Drilling of pilot holes are to be done by fabricator.)

THIS DRAWING WAS CREATED AT NO CHARGE TO ASSIST YOU IN VISUALIZING OUR PROPOSAL. THE DRAWING HEREIN IS THE PROPERTY OF SIGNCOMP. PERMISSION TO COPY OR REVISE THIS DRAWING OR TO USE THIS DRAWING FOR PRODUCTION IS STRICTLY PROHIBITED AND CAN ONLY BE COPIED, REVISED OR USED FOR PRODUCTION WITH THE EXPRESSED WRITTEN PERMISSION OF SIGNCOMP.			<h1>SignComp</h1>	
DRAWN	SBreihof	8/21/2012		
Centroid X:	0.000 in		2Part Large Outer Frame - Reader - Assembly	
Centroid Y:	0.000 in			
Principal Moments Ix:	0.000 in <sup>4</sup>		DWG NO	REV
Principal Moments Iy:	0.000 in <sup>4</sup>		<b>K1941 - Reader</b>	
Section Modulus Ix:	0.000 in <sup>3</sup>		SHEET 1 OF 1	
Section Modulus Iy:	0.000 in <sup>3</sup>			

Ship To:  
Sales Order#:

PARTS LIST			
ITEM	PART #	DESCRIPTION	NOTES
1	1941	2Part Large Outer Frame	
2		Hinge Fastener	1/8" Pop Rivet or #8 Countersink Screw
3	5997	2Part Large Hinge	
4	5993	2Part Large Lock	Drill 3/4" hole - See Detail "A"
5		Large Lock Nut	
6		Lock Spacer	
7		Large Cam	
8		Sprong Washer	
9		Lock Screw	

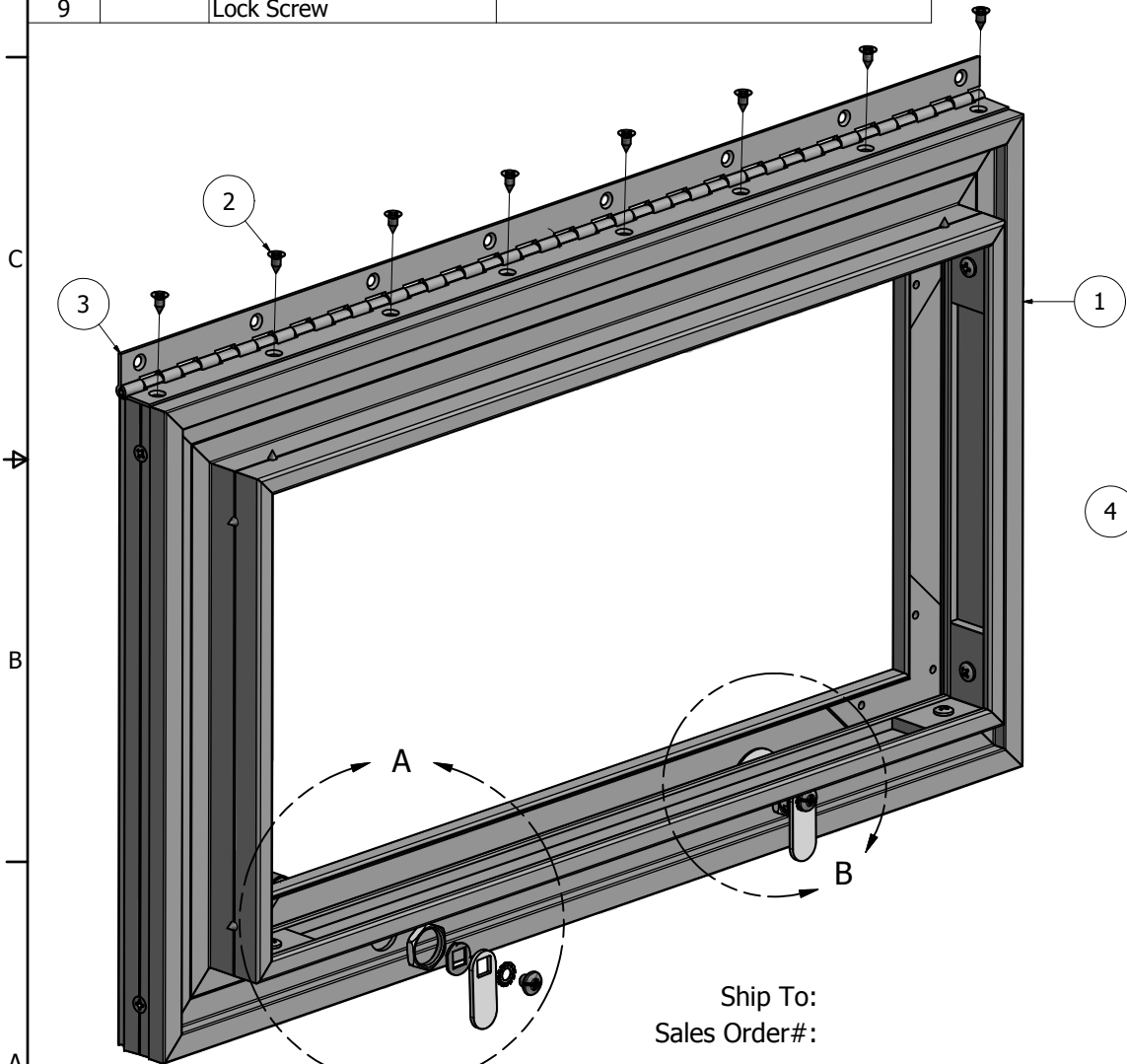

Ship To:  
Sales Order#:

**TIP:** High bond tape or bonding agents can be used to help secure the hinge to the frame and assist in the installation of the hinge. Be careful not to get the tape on the barrel of the hinge. To do so may cause the hinge not to open properly.

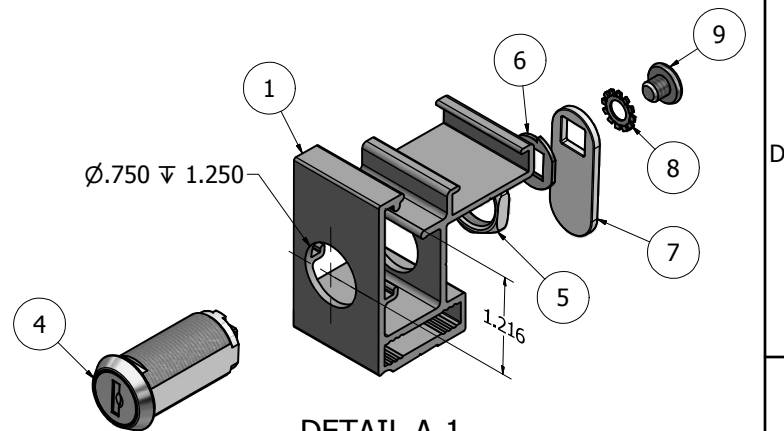

DETAIL A-1

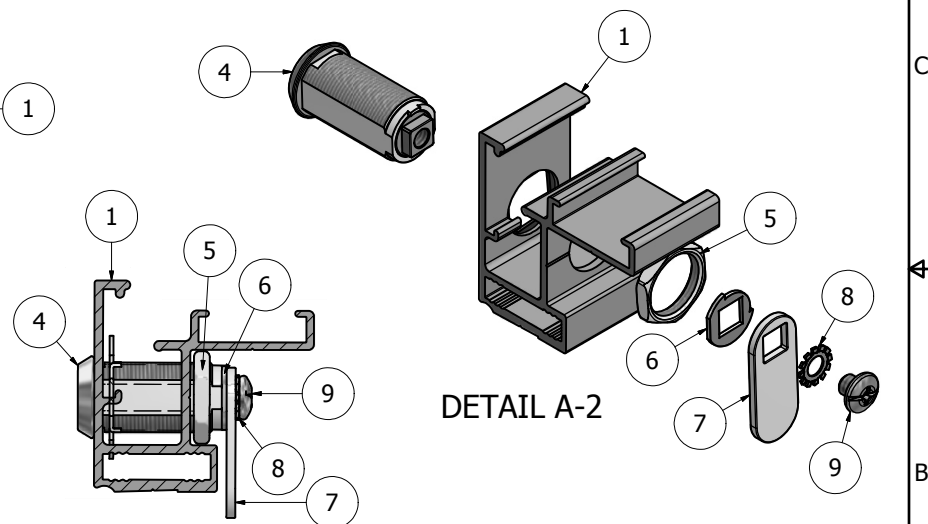

DETAIL A-2

DETAIL B

**NOTE: PRE-CUT KITS ARE NOT PRE-DRILLED.**

(Holes shown in this drawing are for reference only. Drilling of pilot holes are to be done by fabricator.)

THIS DRAWING WAS CREATED AT NO CHARGE TO ASSIST YOU IN VISUALIZING OUR PROPOSAL. THE DRAWING HEREIN IS THE PROPERTY OF SIGNCOMP. PERMISSION TO COPY OR REVISE THIS DRAWING OR TO USE THIS DRAWING FOR PRODUCTION IS STRICTLY PROHIBITED AND CAN ONLY BE COPIED, REVISED OR USED FOR PRODUCTION WITH THE EXPRESSED WRITTEN PERMISSION OF SIGNCOMP.

DRAWN	SBreihof	8/21/2012	<b>SignComp</b>
Centroid X:	0.000 in	TITLE	
Centroid Y:	0.000 in	2Part Outer Frame - 2Part Hinge - 2Part Lock	- Reader Assembly
Principal Moments Ix:	0.000 in^4	DWG NO	
Principal Moments Iy:	0.000 in^4	<b>K1941 - Hinge - Lock - Assembly</b>	REV
Section Modulus Ix:	0.000 in^3	SHEET 1 OF 1	
Section Modulus Iy:	0.000 in^3		

PARTS LIST			
ITEM	PART#	DESCRIPTION	NOTES
1	K1959	2Part Large Inner Frame	Assembly
2	K1941	2Part Large Outer Frame	Assembly
31	5990	2Part Large Hinge Screw	Drill #8 countersink or 1/8" pop rivet

Ship To:  
Sales Order#:

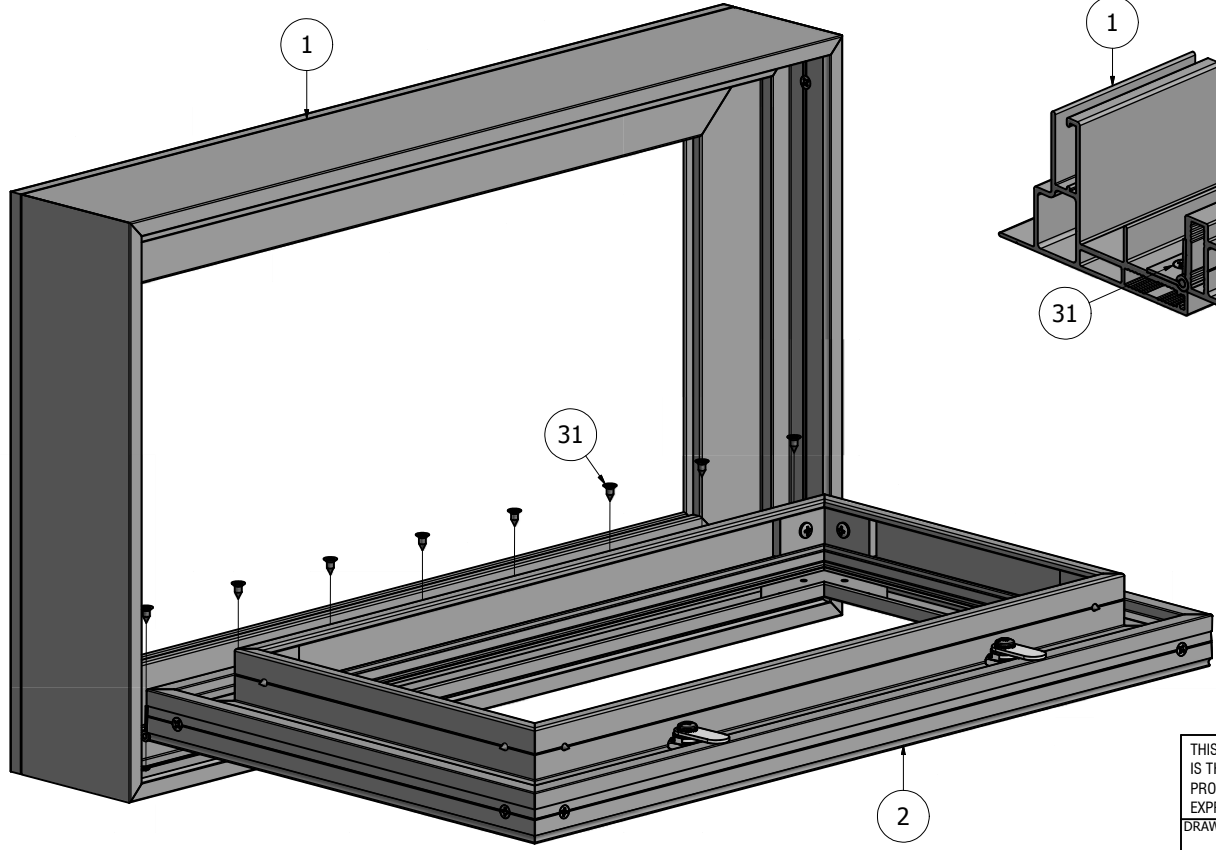
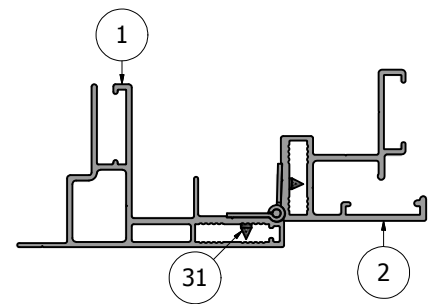
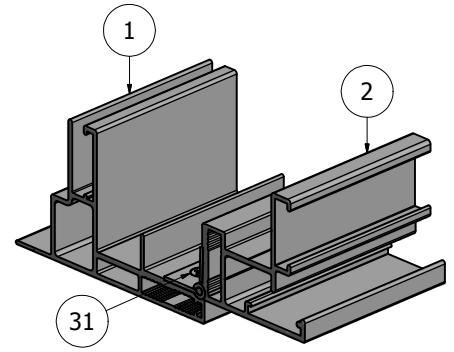
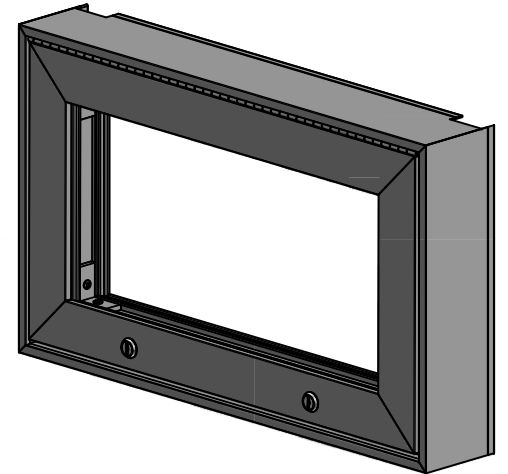
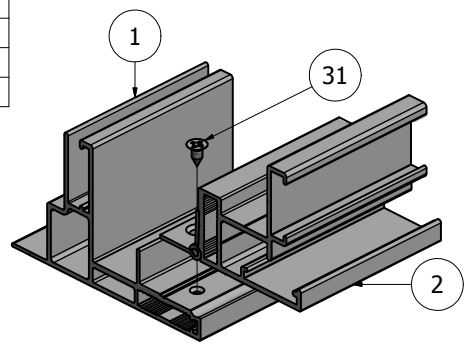

**NOTE: PRE-CUT KITS ARE NOT PRE-DRILLED.**  
(Holes shown in this drawing are for reference only.  
Drilling of pilot holes are to be done by fabricator.)

THIS DRAWING WAS CREATED AT NO CHARGE TO ASSIST YOU IN VISUALIZING OUR PROPOSAL. THE DRAWING HEREIN IS THE PROPERTY OF SIGNCOMP. PERMISSION TO COPY OR REVISE THIS DRAWING OR TO USE THIS DRAWING FOR PRODUCTION IS STRICTLY PROHIBITED AND CAN ONLY BE COPIED, REVISED OR USED FOR PRODUCTION WITH THE EXPRESSED WRITTEN PERMISSION OF SIGNCOMP.		
DRAWN	SBreihof	7/27/2012
Centroid X:	0.000 in	
Centroid Y:	0.000 in	
Principal Moments Ix:	0.000 in^4	
Principal Moments Iy:	0.000 in^4	
Section Modulus Ix:	0.000 in^3	
Section Modulus Iy:	0.000 in^3	
<b>SignComp</b>		TITLE
		2Part Large Inner Frame and 2Part Large Outer Frame - Reader Assembly
DWG NO		REV
<b>K1959/41</b>		
SHEET 1 OF 1		

**TIP:** High bond tape or bonding agents can be used to help secure the hinge to the frame and assist in the installation of the hinge. Be careful not to get the tape on the barrel of the hinge. To do so may cause the hinge not to open properly.